

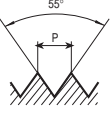

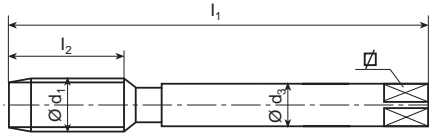





**JUEGOS DE MACHOS A MANO / HAND TAP SETS / JEUX DE TARAUDS À MAIN**

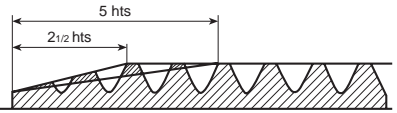





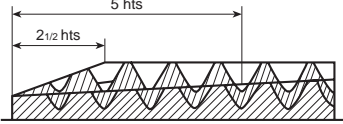
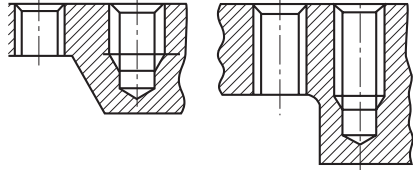
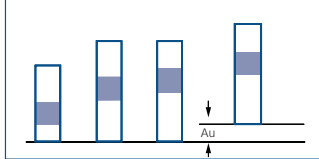

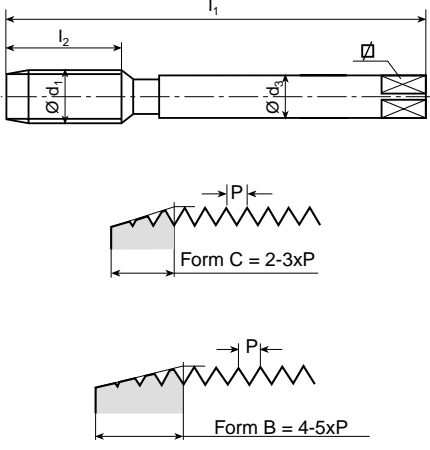
<p><b>BSP</b></p> <p>DIN 11 ROSCA THREAD FILETAGE GAZ WHITWORTH</p> 	<b>STANDARD</b>																																																																																																																																																											
	<b>102</b>	<b>112</b>	<b>132</b>																																																																																																																																																									
<b>HSS</b>																																																																																																																																																												
<b>9531021</b>		<b>9531121</b>	<b>9531321</b>																																																																																																																																																									
	 <p><b>JUEGO DE DOS PIEZAS SET OF TWO TAPS • JEU À DEUX PIÈCES</b></p>		 <p><b>Nº 1</b></p> <p><b>Nº 3</b></p>																																																																																																																																																									
<p><b>HASTA 9/16 PERFIL COMPLETO UP TO 9/16 FULL PROFILE JUSQU'À 9/16 PROFIL COMPLET</b></p> 	<table border="1"> <thead> <tr> <th>d1 Fracc. Pul.</th> <th>P hls/p</th> <th>d1 mm</th> <th>l1 m/m</th> <th>l2 m/m</th> <th>d2 mm</th> <th>∇ mm</th> <th></th> <th></th> </tr> </thead> <tbody> <tr><td>1/16</td><td>28</td><td>7,720</td><td>56</td><td>18</td><td>6,00</td><td>4,90</td><td>6,80</td><td>10</td></tr> <tr><td>1/8</td><td>28</td><td>9,728</td><td>63</td><td>18</td><td>7,00</td><td>5,50</td><td>8,80</td><td>18</td></tr> <tr><td>1/4</td><td>19</td><td>13,158</td><td>70</td><td>20</td><td>11,00</td><td>9,00</td><td>11,80</td><td>36</td></tr> <tr><td>3/8</td><td>19</td><td>16,662</td><td>70</td><td>20</td><td>12,00</td><td>9,00</td><td>15,25</td><td>60</td></tr> <tr><td>1/2</td><td>14</td><td>20,955</td><td>80</td><td>22</td><td>16,00</td><td>12,00</td><td>19,00</td><td>110</td></tr> <tr><td>5/8</td><td>14</td><td>22,911</td><td>80</td><td>22</td><td>18,00</td><td>14,50</td><td>21,00</td><td>180</td></tr> <tr><td>3/4</td><td>14</td><td>26,441</td><td>90</td><td>22</td><td>20,00</td><td>16,00</td><td>24,50</td><td>205</td></tr> <tr><td>7/8</td><td>14</td><td>30,200</td><td>90</td><td>22</td><td>22,00</td><td>18,00</td><td>28,25</td><td>260</td></tr> <tr><td>1"</td><td>11</td><td>33,249</td><td>100</td><td>25</td><td>25,00</td><td>20,00</td><td>30,75</td><td>355</td></tr> <tr><td>1 1/8"</td><td>11</td><td>37,897</td><td>125</td><td>32</td><td>28,00</td><td>22,00</td><td>35,50</td><td>540</td></tr> <tr><td>1 1/4"</td><td>11</td><td>41,910</td><td>125</td><td>32</td><td>32,00</td><td>24,00</td><td>39,50</td><td>780</td></tr> <tr><td>1 3/8"</td><td>11</td><td>44,323</td><td>125</td><td>32</td><td>36,00</td><td>29,00</td><td>42,00</td><td>1000</td></tr> <tr><td>1 1/2"</td><td>11</td><td>47,803</td><td>140</td><td>32</td><td>36,00</td><td>29,00</td><td>25,50</td><td>1100</td></tr> <tr><td>1 5/8"</td><td>11</td><td>51,988</td><td>140</td><td>32</td><td>40,00</td><td>32,00</td><td>49,60</td><td>1250</td></tr> <tr><td>1 3/4"</td><td>11</td><td>53,746</td><td>140</td><td>36</td><td>40,00</td><td>32,00</td><td>51,40</td><td>1300</td></tr> <tr><td>2"</td><td>11</td><td>59,613</td><td>160</td><td>36</td><td>45,00</td><td>35,00</td><td>57,20</td><td>1600</td></tr> </tbody> </table>			d1 Fracc. Pul.	P hls/p	d1 mm	l1 m/m	l2 m/m	d2 mm	∇ mm			1/16	28	7,720	56	18	6,00	4,90	6,80	10	1/8	28	9,728	63	18	7,00	5,50	8,80	18	1/4	19	13,158	70	20	11,00	9,00	11,80	36	3/8	19	16,662	70	20	12,00	9,00	15,25	60	1/2	14	20,955	80	22	16,00	12,00	19,00	110	5/8	14	22,911	80	22	18,00	14,50	21,00	180	3/4	14	26,441	90	22	20,00	16,00	24,50	205	7/8	14	30,200	90	22	22,00	18,00	28,25	260	1"	11	33,249	100	25	25,00	20,00	30,75	355	1 1/8"	11	37,897	125	32	28,00	22,00	35,50	540	1 1/4"	11	41,910	125	32	32,00	24,00	39,50	780	1 3/8"	11	44,323	125	32	36,00	29,00	42,00	1000	1 1/2"	11	47,803	140	32	36,00	29,00	25,50	1100	1 5/8"	11	51,988	140	32	40,00	32,00	49,60	1250	1 3/4"	11	53,746	140	36	40,00	32,00	51,40	1300	2"	11	59,613	160	36	45,00	35,00	57,20	1600
d1 Fracc. Pul.	P hls/p	d1 mm	l1 m/m	l2 m/m	d2 mm	∇ mm																																																																																																																																																						
1/16	28	7,720	56	18	6,00	4,90	6,80	10																																																																																																																																																				
1/8	28	9,728	63	18	7,00	5,50	8,80	18																																																																																																																																																				
1/4	19	13,158	70	20	11,00	9,00	11,80	36																																																																																																																																																				
3/8	19	16,662	70	20	12,00	9,00	15,25	60																																																																																																																																																				
1/2	14	20,955	80	22	16,00	12,00	19,00	110																																																																																																																																																				
5/8	14	22,911	80	22	18,00	14,50	21,00	180																																																																																																																																																				
3/4	14	26,441	90	22	20,00	16,00	24,50	205																																																																																																																																																				
7/8	14	30,200	90	22	22,00	18,00	28,25	260																																																																																																																																																				
1"	11	33,249	100	25	25,00	20,00	30,75	355																																																																																																																																																				
1 1/8"	11	37,897	125	32	28,00	22,00	35,50	540																																																																																																																																																				
1 1/4"	11	41,910	125	32	32,00	24,00	39,50	780																																																																																																																																																				
1 3/8"	11	44,323	125	32	36,00	29,00	42,00	1000																																																																																																																																																				
1 1/2"	11	47,803	140	32	36,00	29,00	25,50	1100																																																																																																																																																				
1 5/8"	11	51,988	140	32	40,00	32,00	49,60	1250																																																																																																																																																				
1 3/4"	11	53,746	140	36	40,00	32,00	51,40	1300																																																																																																																																																				
2"	11	59,613	160	36	45,00	35,00	57,20	1600																																																																																																																																																				
<p><b>MAYORES 9/16 PERFIL ESCALONADO LARGER THAN 9/16 STEPPED PROFILE PLUS GRANDS QUE 9/16 PROFIL ÉCHELONNÉ</b></p> 																																																																																																																																																												
<p><b>TIPOS DE ORIFICIO TYPE OF HOLE • GEOMETRIE DU TROU</b></p> 																																																																																																																																																												
<p><b>TOLERANCIAS • TOLERANCES • TOLERANCES</b></p> 																																																																																																																																																												







**BSP**



<h1>BSP</h1>	DIN 11 ROSCA THREAD FILETAGE GAZ WHITWORTH		<b>CLASE / CLASS HSSE</b>	
			<table border="1" style="width: 100%; border-collapse: collapse;"> <tr> <td style="text-align: center; width: 50%;"><b>ESTRIAS RECTAS STRAIGHT FLUTES GOUJURES DROITES</b></td> <td style="text-align: center; width: 50%;"><b>ESTRIAS RECTAS FORMA B GUN NOSE FORM B GOUJURES DROITES FORME B</b></td> </tr> </table>	<b>ESTRIAS RECTAS STRAIGHT FLUTES GOUJURES DROITES</b>
<b>ESTRIAS RECTAS STRAIGHT FLUTES GOUJURES DROITES</b>	<b>ESTRIAS RECTAS FORMA B GUN NOSE FORM B GOUJURES DROITES FORME B</b>			



ACABADO / FINISH / ASPECT FORMA / FORM / FORME REFERENCIA / REFERENCE CODIGO / CODE	B		U		TIN		TICN	
	FORMA C				FORMA B			
	301	050	391	371	302	342	392	372
	9633011	9630501	9633911	9633711	9633021	9633421	9633921	9633721

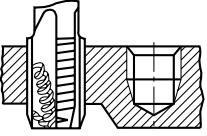
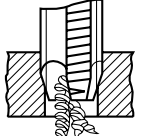

							
--	--	--	---	--	--	--	--

Material a trabajar / Work mat. / Mat. a travailler (ref. pag. 10)								
--	---	---	---	--	---	---	---	---

TIPOS DE ORIFICIO TYPE OF HOLE • GEOMETRIE DU TROU	d1	P	d1	l1	l2	d2	mm		
	Frc. / Pul	m/m	m/m	m/m	m/m	mm	mm		
<b>FORMA C • FORM C • FORME C</b>  <b>FORMA B • FORM B • FORME B</b> 	<b>1/16</b>	28	7,720	90	18	6,00	4,90	6,80	10
	<b>1/8</b>	28	9,728	90	18	7,00	5,50	8,80	18
	<b>1/4</b>	19	13,158	100	22	11,00	9,00	11,80	36
	<b>3/8</b>	19	16,662	100	25	12,00	9,00	15,30	60
	<b>1/2</b>	14	20,955	125	25	16,00	12,00	19,00	110
	<b>5/8</b>	14	22,911	125	25	18,00	14,50	21,00	180
	<b>3/4</b>	14	26,441	140	28	20,00	16,00	24,50	205
	<b>7/8</b>	14	30,200	150	28	22,00	18,00	28,30	260
	<b>1"</b>	11	33,249	160	36	25,00	20,00	30,80	355
	<b>1 1/8"</b>	11	37,897	170	36	28,00	22,00	35,50	540

RECUBRIMIENTOS • COATINGS • REVETEMENT	d1	P	d1	l1	l2	d2	mm		
	Frc. / Pul	m/m	m/m	m/m	m/m	mm	mm		
<b>B = BRILLANTE/BRIGHT/BLANC</b> <b>U= URDIN/ VAPORIZED/STEAM HOMO</b> <b>TIN= NITRURO DE TITANIO/TITANIUM NITRIDE</b> <b>TICN= CARBONITRURO DE TITANIO</b> <b>TITANIUM CARBONITRIDE</b> <b>OTROS RECUBRIMIENTOS BAJO DEMANDA • OTHER COATINGS ON</b> <b>REQUEST • D'AUTRES RECOUVREMENTS SOUS DEMANDE</b>	<b>1 1/2"</b>	11	47,803	190	40	36,00	29,00	25,50	1100
	<b>1 5/8"</b>	11	51,988	190	40	40,00	32,00	49,60	1250
	<b>1 3/4"</b>	11	53,746	190	40	40,00	32,00	51,40	1300
	<b>2"</b>	11	59,613	220	40	45,00	35,00	57,20	1600



**CALIDAD • QUALITY • QUALITE**

Una completa Garantía de Calidad exige la comprobación sistemática de los orificios roscados

For a complete Quality Guarantee it is necessary to do a systematic check of holes talled

Pour une total Garantie Qualité il faut verifier systematicament les trous taraudees

BSP

<h1>BSP</h1>	<b>DIN 11</b> ROSCA THREAD FILETAGE GAZ WHITWORTH		<b>CLASE / CLASS HSSSE (PM)</b>			
			<b>ESTRIAS RECTAS</b> <b>STRAIGHT FLUTES</b> <b>GOUJURES DROITES</b>	<b>ESTRIAS RECTAS FORMA B</b> <b>GUN NOSE FORM B</b> <b>GOUJURES DROITES FORME B</b>		

ACABADO / FINISH / ASPECT FORMA / FORM / FORME REFERENCIA / REFERENCE CODIGO / CODE	B	U	TIN	TICN	B	U	TIN	TICN
	FORMA C				FORMA B			
	601	031	691	081	602	642	692	082
	9636011	9636111	9636911	9630811	9636021	9636421	9636921	9630821

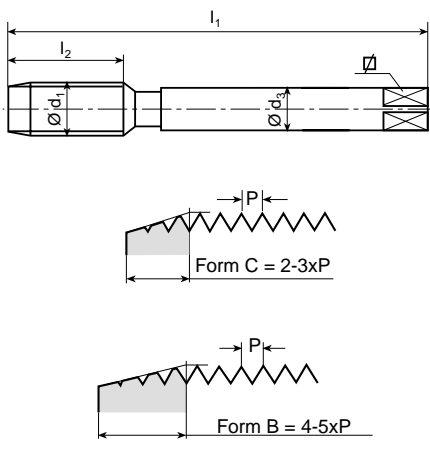

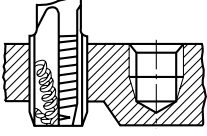
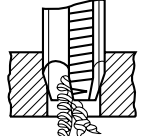

Material a trabajar / Work mat. / Mat. a travailler (ref. pag. 10)								
--	--	--	--	--	--	--	--	--

TIPOS DE ORIFICIO TYPE OF HOLE • GEOMETRIE DU TROU	d1	P	d1	l1	l2	d2	mm	mm	mm	mm
	Frc/Pul	m/m	m/m	m/m	m/m	mm	mm	mm	mm	mm
<b>FORMA C • FORM C • FORME C</b>  <b>FORMA B • FORM B • FORME B</b> 	1/16	28	7,720	90	18	6,00	4,90	6,80	10	
	1/8	28	9,728	90	18	7,00	5,50	8,80	18	
	1/4	19	13,158	100	22	11,00	9,00	11,80	36	
	3/8	19	16,662	100	25	12,00	9,00	15,30	60	
	1/2	14	20,955	125	25	16,00	12,00	19,00	110	
	5/8	14	22,911	125	25	18,00	14,50	21,00	180	
	3/4	14	26,441	140	28	20,00	16,00	24,50	205	
	7/8	14	30,200	150	28	22,00	18,00	28,30	260	
	1"	11	33,249	160	36	25,00	20,00	30,80	355	
	1 1/8"	11	37,897	170	36	28,00	22,00	35,50	540	

RECUBRIMIENTOS • COATINGS • REVETEMENT	d1	P	d1	l1	l2	d2	mm	mm	mm	mm
	Frc/Pul	m/m	m/m	m/m	m/m	mm	mm	mm	mm	mm
<b>B = BRILLANTE/BRIGHT/BLANC</b> <b>U= URDIN/ VAPORIZADO/STEAM HOMO</b> <b>TIN= NITRURO DE TITANIO/TITANIUM NITRIDE</b> <b>TICN= CARBONITRURO DE TITANIO</b> <b>TITANIUM CARBONITRIDE</b>  <b>OTROS RECUBRIMIENTOS BAJO DEMANDA • OTHER COATINGS ON</b> <b>REQUEST • D' AUTRES RECOUVREMENTS SOUS DEMANDE</b>	1 1/2"	11	47,803	190	40	36,00	29,00	25,50	1100	
	1 5/8"	11	51,988	190	40	40,00	32,00	49,60	1250	
	1 3/4"	11	53,746	190	40	40,00	32,00	51,40	1300	
	2"	11	59,613	220	40	45,00	35,00	57,20	1600	



**CALIDAD • QUALITY • QUALITE**

Una completa Garantía de Calidad exige la comprobación sistemática de los orificios roscados

For a complete Quality Guarantee it is necessary to do a systematic check of holes talled

Pour une total Garantie Qualité il faut verifier systematicament les trous taraudees

BSP

BSP	DIN 11 ROSCA THREAD FILETAGE GAZ WHITWORTH		CLASE / CLASS HSSEE (PM)	
			<b>ESTRIAS HEL.15°≈ STRAIGHT FLUTES 15°≈ GOUJURES HEL. 15°≈</b>	<b>ESTRIAS HELICOIDALES 35°≈ SPIRAL FLUTE 35°≈ GOUJURES HELICOIDALE 35°≈</b>

ACABADO / FINISH / ASPECT FORMA / FORM / FORME REFERENCIA / REFERENCE CODIGO / CODE	B	U	TIN	TICN	B	U	TIN	TICN
	FORMA C							
	603	643	693	083	605	645	695	085
	9636031	9636431	9636931	9630831	9636051	9636451	9636951	9630951

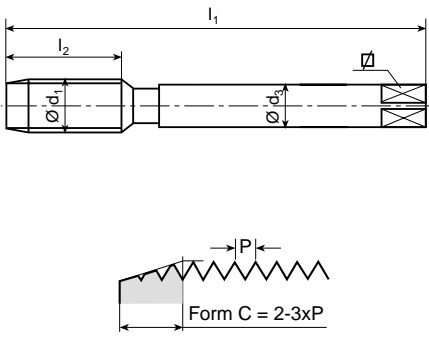

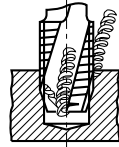

Material a trabajar / Work mat. / Mat. a travailler (ref. pag. 10)	
--	--

TIPOS DE ORIFICIO TYPE OF HOLE • GEOMETRIE DU TROU HELICE 15° • SPIRAL 15° • HÉLICE 15°	d1 Frc. / Pul	P m/m	d1 m/m	l1 m/m	HEL.15°		HEL.35°		d2 mm	mm		
					l2 m/m	l3 m/m	mm	mm				
	1/16	28	7,720	90	18	12	6,00	4,90	6,80	10		
	1/8	28	9,728	90	18	12	7,00	5,50	8,80	18		
	1/4	19	13,158	100	22	16	11,00	9,00	11,80	36		
	3/8	19	16,662	100	25	18	12,00	9,00	15,30	60		
	1/2	14	20,955	125	25	20	16,00	12,00	19,00	110		
	5/8	14	22,911	125	25	20	18,00	14,50	21,00	180		
	3/4	14	26,441	140	28	22	20,00	16,00	24,50	205		
	7/8	14	30,200	150	28	22	22,00	18,00	28,30	260		
	1"	11	33,249	160	36	25	25,00	20,00	30,80	355		
	1 1/8"	11	37,897	170	36		28,00	22,00	35,50	540		
	1 1/4"	11	41,910	170	40		32,00	24,00	39,50	780		
	1 3/8"	11	44,323	180	40		36,00	29,00	42,00	1000		
	1 1/2"	11	47,803	190	40		36,00	29,00	25,50	1100		
	1 5/8"	11	51,988	190	40		40,00	32,00	49,60	1250		
	1 3/4"	11	53,746	190	40		40,00	32,00	51,40	1300		
	2"	11	59,613	220	40		45,00	35,00	57,20	1600		

<b>RECUBRIMENTOS • COATINGS • REVETEMENT</b>  B = BRILLANTE/BRIGHT/BLANC U= URDIN/ VAPORIZED/STEAM HOMO TIN= NITRURO DE TITANIO/TITANIUM NITRIDE TICN= CARBONITRURO DE TITANIO TITANIUM CARBONITRIDE  OTROS RECUBRIMENTOS BAJO DEMANDA • OTHER COATINGS ON REQUEST • D' AUTRES RECOUVREMENTS SOUS DEMANDE												
--	--	--	--	--	--	--	--	--	--	--	--	--



CALIDAD • QUALITY • QUALITE

Una completa Garantía de Calidad exige la comprobación sistemática de los orificios roscados

For a complete Quality Guarantee it is necessary to do a systematic check of holes talled

Pour une total Garantie Qualité il faut verifier systematicament les trous taraudees